



BNL-90770-2010-CP

*Simulation of the high-pass filter for 56MHz cavity
for RHIC*

Q. Wu, I. Ben-Zvi

Presented at the First International Particle Accelerator Conference (IPAC'10)
Kyoto, Japan
May 23-28, 2010

Collider-Accelerator Department

Brookhaven National Laboratory

P.O. Box 5000
Upton, NY 11973-5000
www.bnl.gov

Notice: This manuscript has been authored by employees of Brookhaven Science Associates, LLC under Contract No. DE-AC02-98CH10886 with the U.S. Department of Energy. The publisher by accepting the manuscript for publication acknowledges that the United States Government retains a non-exclusive, paid-up, irrevocable, world-wide license to publish or reproduce the published form of this manuscript, or allow others to do so, for United States Government purposes.

This preprint is intended for publication in a journal or proceedings. Since changes may be made before publication, it may not be cited or reproduced without the author's permission.

DISCLAIMER

This report was prepared as an account of work sponsored by an agency of the United States Government. Neither the United States Government nor any agency thereof, nor any of their employees, nor any of their contractors, subcontractors, or their employees, makes any warranty, express or implied, or assumes any legal liability or responsibility for the accuracy, completeness, or any third party's use or the results of such use of any information, apparatus, product, or process disclosed, or represents that its use would not infringe privately owned rights. Reference herein to any specific commercial product, process, or service by trade name, trademark, manufacturer, or otherwise, does not necessarily constitute or imply its endorsement, recommendation, or favoring by the United States Government or any agency thereof or its contractors or subcontractors. The views and opinions of authors expressed herein do not necessarily state or reflect those of the United States Government or any agency thereof.

SIMULATION OF THE HIGH-PASS FILTER FOR 56MHZ CAVITY FOR RHIC *

Q. Wu[#] and I. Ben-Zvi, BNL, Upton, NY 11973, U.S.A.

Abstract

The 56MHz Superconducting RF (SRF) cavity for RHIC places high demands High Order Mode (HOM) damping, as well as requiring a high field at gap with fundamental mode frequency. The damper of 56MHz cavity is designed to extract all modes to the resistance load outside, including the fundamental mode. Therefore, the circuit must incorporate a high-pass filter to reflect back the fundamental mode into the cavity. In this paper, we show the good frequency response map obtained from our filter's design. We extract a circuit diagram from the microwave elements that simulate well the frequency spectrum of the finalized filter. We also demonstrate that the power dissipation on the filter over its frequency range is small enough for cryogenic cooling.

INTRODUCTION

The design of RHIC's 56MHz SRF cavity, with its large bucket, reduces spill from the beam [1]. However, its successful performance depends greatly on damping the HOMs. Accordingly, we expended much effort in designing the HOM damper loops and configuring their location [2]. The damper loops will couple out all the modes from the cavity, including the fundamental mode. With the damper loops inserted, the Q_L of the fundamental mode will drop to about 10^3 . Compared to the designed Q_L of 4×10^7 , this will send a dangerously large amount of power into the HOM damper load. Our previous simulations showed that the frequency difference between the fundamental mode and the first HOM is large [2], i.e., greater than 100MHz; thus, we designed and incorporated a high-pass filter into the circuit to reflect the fundamental mode.

HIGH-PASS FILTER

The filter is designed as a 2 stage high-pass filter to simplify the manufacturing process. We use a Chebyshev T-Type design to obtain a steeper roll-off and minimize the error between the designed and the actual object.

Error! Reference source not found. shows the preliminary model of the filter. Port 1 is the connection port to the damper's loop, and port 2 is the filter's output. Two coaxial sapphire rings, shown green in the figure, with niobium spacers constitute the two capacitors in the design; the three inductors are niobium rods with carefully chosen lengths and locations. Sapphire is chosen due to its low loss tangent, to reduce heat dissipation in the HOM damper due to dielectric heating. For better conductive cooling of the loop, the filter is designed with an inductor first, as shown in the simplified circuit

diagram in Figure 2, with lumped RLC elements, viz., connected resistor, inductor, and capacitor. Thus, the coupled RF wave encounters the inductor first, which is a thin rod of niobium connecting the inner and outer conductor of the damper loop. The inductor rod serves as a cooling path for the HOM damper.

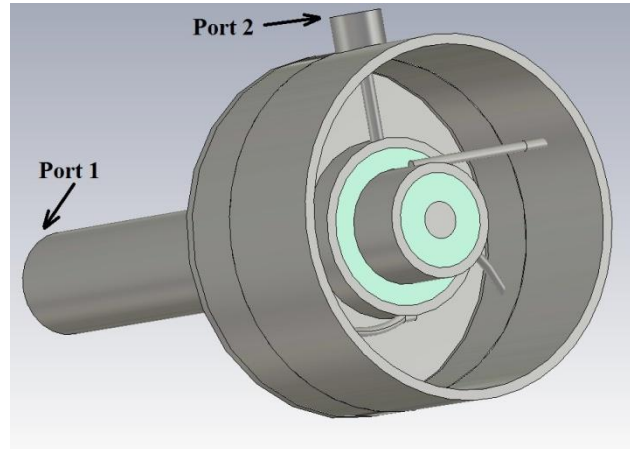

Figure 1: Preliminary design of high-pass filter for the HOM damper of 56MHz SRF cavity.

We estimated the values in the RLC circuit for the ideal response of the filter. We based the dimensions of the sapphire rings and niobium rods in the model design on their theoretical value in the RLC circuit. In the simulation model, the large surrounding niobium ring and the connections between ports introduces extra capacitance and inductance. Accordingly, the finalized dimensions of the elements had minor changes from the theoretical ones.

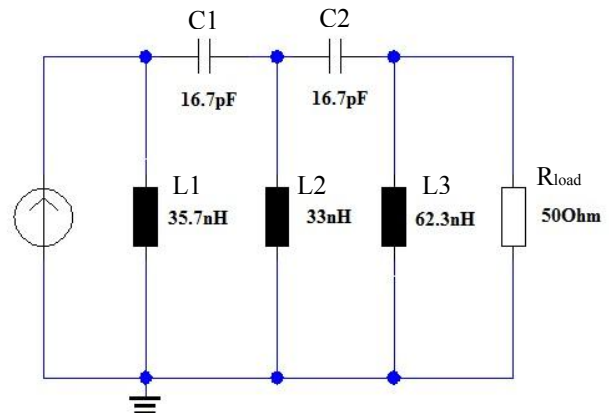

Figure 2: Simplified RLC circuit for high-pass filter.

* This work was supported by Brookhaven Science Associates, LLC under Contract No. DE-AC02-98CH10886 with the U.S. DOE
[#]qiowu@bnl.gov

Figure 3 plots the response spectrum of the modelled filter. The blue curve shows the S21 between the two ports described above, (i.e., the response at port 2 due to a signal at port 1). The vertical black lines label all the possible mode frequencies in the cavity. The blue curve at -68dB intersects the fundamental mode of 56MHz, while the attenuation of the first HOM of 168MHz has dropped to less than -5dB. The filter response is very constant up to 1GHz after the first HOM. According to Figure 3, the high-pass filter of this specific model has a very good performance.

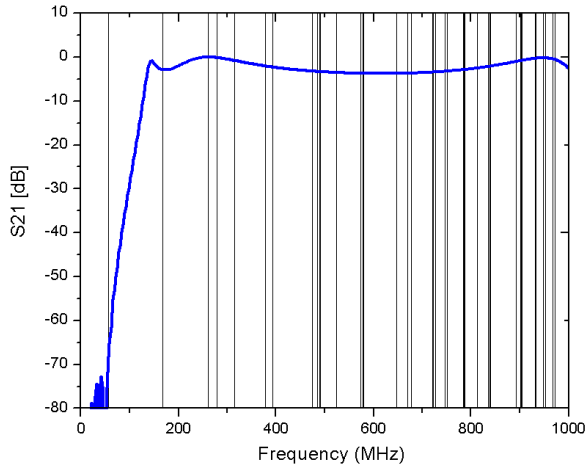

Figure 3: Response spectrum of the high-pass filter.

Figure 4 shows that the S21 of the simplified RLC circuit and the result of the model simulation correspond very well.

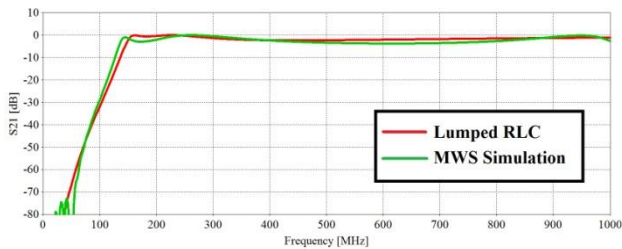

Figure 4: Comparison of S21 between the simplified RLC circuit and the MWS simulation.

Engineering Model of the Filter

The model for manufacturing the filter will include many more components including those for vacuum sealing, cooling liquid helium, and RF power shielding. The engineering design of the filter will be much more complicated and the dimensions will require more changes.

The simulation of the realistic structure is much more complicated than the ideal case because of the inclusion of the all the extra components. The sapphire feedthrough

tubes will seal the cavity's vacuum by hermetically closing the opening of the loop conductor. Thus, the high voltage between the inner and outer conductor of the HOM damper loop limits the length of the tube. The sapphire cooling tubes will provide the flow of liquid helium for cooling the damper and filter; therefore they also need to be able to hold the high voltage. There will be a niobium canister on the outside of the filter (not shown in Figure 5) that shields the RF power; it also will add extra capacitance to the system.

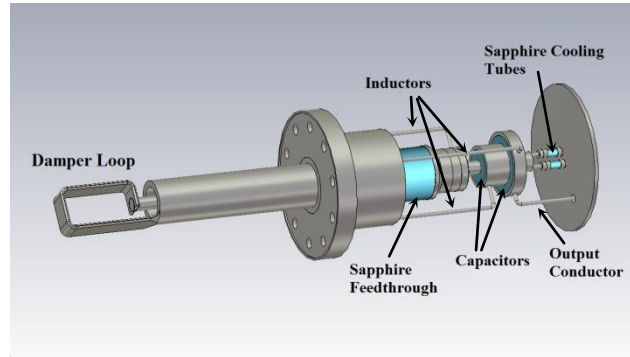

Figure 5: Engineering model of the filter.

We are in the process of optimizing the parameters of the engineering model; and the current S21 for fundamental mode is close to -60dB, with less than -15dB attenuation for all HOMs.

Fundamental Mode Power

With the designed gap voltage of 2.5 MV, the stored energy in the cavity will be 216 J. The power loss at the HOM damper ports is

$$P_{\text{loss}} = \frac{2\pi f_0 U_{\text{store}}}{Q_L} \quad (1)$$

where f_0 is the fundamental mode frequency of the cavity, which is 56 MHz, Q_L is the loaded Q of the port. The findings from the MICROWAVE STUDIO simulation suggest that without the filter, Q_L would be 940, combining the losses from all four dampers. Taking into account that the results from this preliminary model, the high-pass filter would provides an attenuation of $a = -68\text{dB}$ at f_0 . The power extracted from the fundamental mode then should be:

$$P_{\text{loss}} = \frac{2\pi f_0 U_{\text{store}}}{Q_L 10^{a/10}} = 12.8\text{W} \quad (2)$$

The power on each damper is only 3.2 W. This load can be easily handled by the coax transmission line, which will be used to transfer the power from the cold (4.5 K) coupler to a termination at room temperature.

HOM Power

In an actual case only the excited modes in the cavity determine HOM power. In this paper, we describe a calculation of which all possible HOMs are excited, that is, the worst-case scenario.

For 250 GeV proton operation in RHIC, the current of a circulating beam with Gaussian bunches is

$$I(t) = \sum_{m=-\infty}^{\infty} \sum_{j=1}^{N_h} \frac{Ne}{\sqrt{2\pi\sigma_t^2}} \exp\left[-\frac{(t-mT_0-jT_0/N_h)^2}{2\sigma_t^2}\right] \quad (3)$$

where N is the number of particles per bunch, T_0 is the revolution period, N_h is the number of bunches, and σ_t is the rms bunch length. To obtain the excitation for each HOM, we apply a Fourier Expansion to Equation (3)

$$I(t) = \sum_{n=-\infty}^{\infty} C_n \exp\left[-i\frac{2\pi nt}{T_0}\right] = \sum_{n=-\infty}^{\infty} C_n \exp[-in\omega_0 t] \quad (4)$$

where

$$C_n = \frac{1}{T_0} \int_0^{T_0} I(t) \exp[-in\omega_0 t] dt \quad (5)$$

It is certain that $\sigma_t \ll T_0$. Thus only the $m=0$ term contributes. C_n then is solved from Equation (5)

$$\begin{aligned} C_n &= \frac{Ne}{T_0} \int_0^{T_0} \frac{1}{\sqrt{2\pi\sigma_t^2}} \exp\left[-\frac{(t-jT_0/N_h)^2}{2\sigma_t^2}\right] \exp[-in\omega_0 t] dt \\ &= \frac{Ne}{T_0} \sum_{j=1}^{N_h} \exp[-i\frac{2\pi nj}{N_h}] \exp\left[-\left(\frac{2\pi}{T_0}\right)^2 n^2 \frac{\sigma_t^2}{2}\right] \end{aligned}$$

It is easy to verify that only when n/N_h is an integer, C_n has a non-zero value of

$$C_n = \frac{Ne\omega_h}{2\pi} \exp\left[-\frac{m^2 \omega_h^2 \sigma_t^2}{2}\right] \quad (6)$$

where ω_h is the bunch frequency. Equation (4) shows that C_n is the n -th harmonic component for the beam's current. The excited power for HOM in the cavity is determined by the product of the real part of the impedance of each mode $Re[Z(\omega)]$ and C_n^2 . Therefore, for the k -th mode in the cavity

$$Re[Z_{n,k}(\omega)] = \frac{(R/Q)_k Q_k}{1 + Q_k^2 \left(\frac{\omega_k}{n\omega_0} - \frac{n\omega_0}{\omega_k}\right)^2} \quad (7)$$

$$P_k = 4 \sum_{n=-\infty}^{\infty} Re[Z_{n,k}(\omega)] C_n^2$$

where P_k is the power of the k -th mode in the cavity excited by the beam.

Table 1: Parameters for 250GeV proton operation in RHIC.

Parameter	Value	Unit
Beam Energy	250	GeV
Revolution frequency	78.2	kHz
Particle per Bunch	2.0	10^{11}
rms Bunch Length	0.2	m
Bunch Number	120	

We programmed a simple code to calculate the power for each HOM. The parameters for this calculation are listed in **Error! Reference source not found.** The program also can scan the frequency in a small range adjacent each HOM and select the maximum power. For all HOMs below 1GHz, the total power extracted is 4.3W, which is about 1.1W per HOM damper. This number should be doubled considering both beams passing through the same cavity. We also noted that most of the HOM power is contributed by the 1st HOM with 4.26W; rest of the modes contribute a very small amount. Hence, it is reasonable to neglect the modes above 1GHz.

Together with the power from the fundamental mode, each HOM damper extracts no more than $3.2 + 1.1 \times 2 = 5.4W$. The cryogenic cooling system easily can handle this value can be easily handled by the cryogenic cooling system, leaving us great flexibility in optimizing the engineering model.

SUMMARY

The high-pass filter for 56MHz SRF cavity shows very good response spectrum over the range up to 1GHz. The power dissipated in the filter should be less than 5W per damper, and this is easy to deal with for HOM dampers with liquid helium cooling loops.

ACKNOWLEDGEMENT

The authors would like to thank S. Bellavia, G. Miglionico, and C. Pai for providing engineering drawing of the filter, as well as helpful discussions.

REFERENCES

- [1] I. Ben-Zvi, *Superconducting Storage Cavity for RHIC*, Tech. Rep. 337 (Brookhaven National Laboratory, Upton, NY 11973 USA, 2004).
- [2] Q. Wu and I. Ben-Zvi, *Optimization of Higher Order Mode Dampers in the 56 MHz SRF Cavity for RHIC*, these proceedings.
- [3] CST Microwave Studio Suite 2010.