

Design, Construction and Test of Cryogen-Free HTS Coil Structure*

H. Hocker, M. Anerella, R. Gupta, S. Plate, W. Sampson, J. Schmalzle, Y. Shiroyanagi, BNL, Upton, New York 11973, U.S.A.

Abstract

This paper will describe design, construction and test results of a cryo-mechanical structure to study coils made with the second generation High Temperature Superconductor (HTS) for the Facility for Rare Isotope Beams (FRIB). A magnet comprised of HTS coils mounted in a vacuum vessel and conduction-cooled with Gifford-McMahon cycle cryocoolers is used to develop and refine design and construction techniques. The study of these techniques and their effect on operations provides a better understanding of the use of cryogen free magnets in future accelerator projects. A cryogen-free, superconducting HTS magnet possesses certain operational advantages over cryogenically cooled, low temperature superconducting magnets.

CONSTRUCTION DETAILS

Six coils have been constructed with the second generation (2G) HTS based on essentially the same geometry that was earlier used in making twenty five coils with the first generation HTS [1] for Facility for Rare Isotope Beams [2]. Four of these coils are made with 100 meter of ~4 mm wide and ~0.3 mm thick HTS tape from American Superconductor Corporation (ASC) and two with 100 meter of ~4 mm wide and ~0.1 mm thick tape from SuperPower. SuperPower coils (smaller in width) are put in middle of the six coil pack.

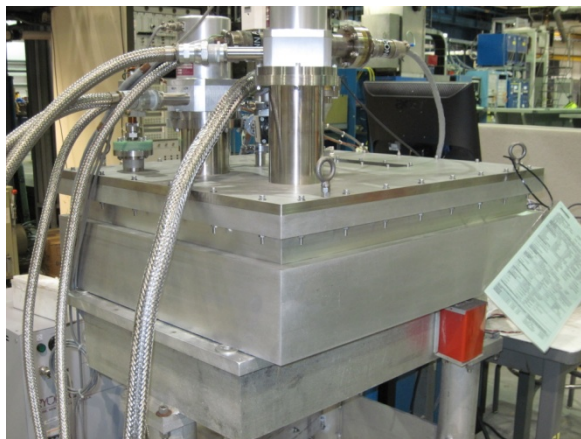

Figure 1: Completed Magnet

The six-coil pack is constrained by an assembly of ten aluminum plates which align the coils and provide the desired preload to the coil stack. See Figure 2. This coil box (cold mass) is suspended from the stainless steel cryostat lid using G-10 links to minimize heat leak (See Figure 3 & Figure 4). Design of the coil pack,

surrounding aluminum, and the enclosing cryostat structure contain a rectangular inner opening allowing for addition of warm iron in the future.

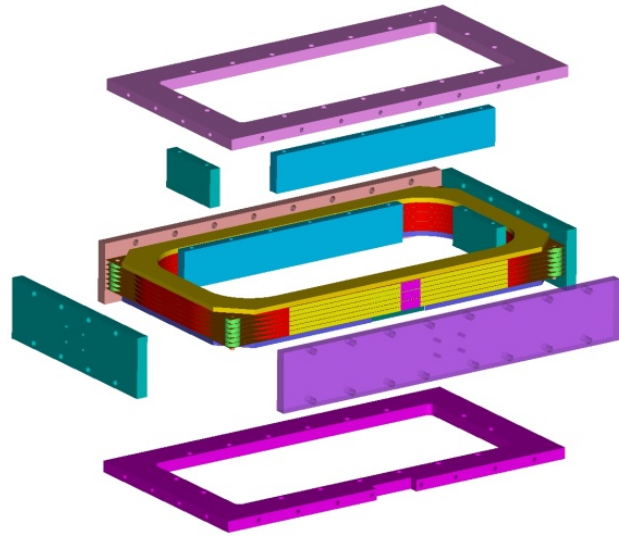

Figure 2: Cold Mass Box with 6-Coil Pack

The lid has welded attachments allowing for connection of the cryocoolers, leads, instrumentation, pump-out port, and pressure relief. The cryostat volume is completed by attachment of the lid assembly to an aluminium cryostat box, machined from solid aluminium billet without welding. Attachment of the lid to the cryostat box is accomplished with fasteners and an O-Ring seal. This method allows for simple disassembly for inspection or changes. The cold mass is connected thermally to the first of two Gifford-McMahon (G-M) Cryocoolers [3] using two laminated straps fabricated from .010" (0.25 mm) thick copper strips, attached to opposite ends of the cold mass. Using laminated sheets instead of a solid bus provides sufficient flexibility to account for thermal shrinkage. Coil electrical leads and external power leads all terminate at a copper power lead head (See Figure 4). The lead head is connected to the second G-M cryocooler. Thin Kapton sheets electrically isolate the cryocooler head from the energized copper lead terminations. Leads travelling to the outside of the magnet have been length-optimized to minimize both heat leak and internal heat generation in those non-superconducting regions and are cooled only by conduction from the cryocooler.

The system is designed to test coils up to a current of 500A. By assuming a set of end temperatures for the magnet leads, the length-optimization calculation provided the lead length which would offer the minimum heat generation with those end temperatures. Assuming lead temperatures of 293K & 80K, the optimization anticipated a load of 29W for each lead @ operating

*This work is supported by the U.S. Department of Energy under Contract No. DE-AC02-98CH10886 and under Cooperative Agreement DE-SC0000661 from DOE-SC that provides financial assistance to MSU to design and establish FRIB.

current. Using separate cryocoolers for the leads and the coil box allow for operation of the lead cryocooler at higher temperature than that required for coil operations. In this way, the design could take advantage of the cryocoolers increased capacity in that range. Since cooling was entirely dependent on conduction, joints were considered critical. Apiezon-N vacuum grease [4] was used as an interposer in the bolted connections to increase thermal conductivity. At these connections, maximum torque was used in conjunction with Belleville washers, to maintain contact pressure at operational temperatures. Temperature instrumentation was provided by silicon diodes placed at thirty two locations within the magnet structure. As thermal behaviour of the joints was of particular interest, diodes were placed at nearly all of the junctions in the heat-path. Additional diodes were located on the coils, the cryocooler ends, the leads, and one of the G-10 straps holding up the magnet. Redundant sensors were placed at a number of locations. This was done to study consistency in readings and to confirm the effectiveness of the various attachment methods used for locating the diodes.



Figure 3: Underside of Magnet Lid

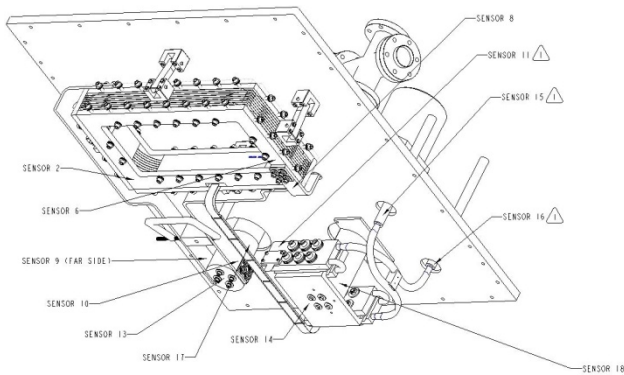

Figure 4: Sensor Locations (Bottom-side) – Similar locations topside were also instrumented along with coils and G-10 Hanger

OPERATIONAL RESULTS

Initial operations involved cooling without application of current. After pump-down and cryocooler activation, steady state was reached in approximately 20 hours (see Figure 5). Select steady state temperatures are given in Table 1. Select temperature gradients at heat-carrying mechanical connections are given in Table 2. Table 3 shows actual vs. analysis generated temperatures for selected points in the magnet. Table 4 shows values of conductance used in obtaining the values in Table 3.

Table 1: Select Steady State Temperatures

Location	Temperature (K)
Lead 1 - Warm End /Cold End	248 /42
Lead 2 - Warm End /Cold End	247 /42
Cryocooler Head (Coil)	26
Cryocooler Head (Leads)	33
Coil (Average)	39
Coil Box (Range)	29 - 38

Table 2: Select ΔT for Mechanical Connections

Location	ΔT (K)Range
Cryocooler Head – Copper Block	0-1.3
Copper - Copper (2 Mil Kapton Interposer)	7.7-8.7
Copper - Copper (Apiezon-N Interposer)	<.1
Copper - Aluminium (Apiezon-N Interposer)	1.8-4.8

Table 3: Comparison Operational /Unpowered vs. Calculated Temperatures (Selected)

Location	Estimated (K)	Actual (K)
Cold Mass Box	34	29-38
Thermal Straps @Cold Mass	33	28
Coil	35	39

Table 4: Assumed Contact Conductance Across Joints for Calculated Temperature (*)

Joint Description	(W/mm ² K)
Cold Mass Box-Cryocooler Strap	5×10^{-3}
Cold Mass Box to Coil	1×10^{-3}
Joints where good transfer is not wanted	∞

*Estimated heat input through MLI=1.0 W

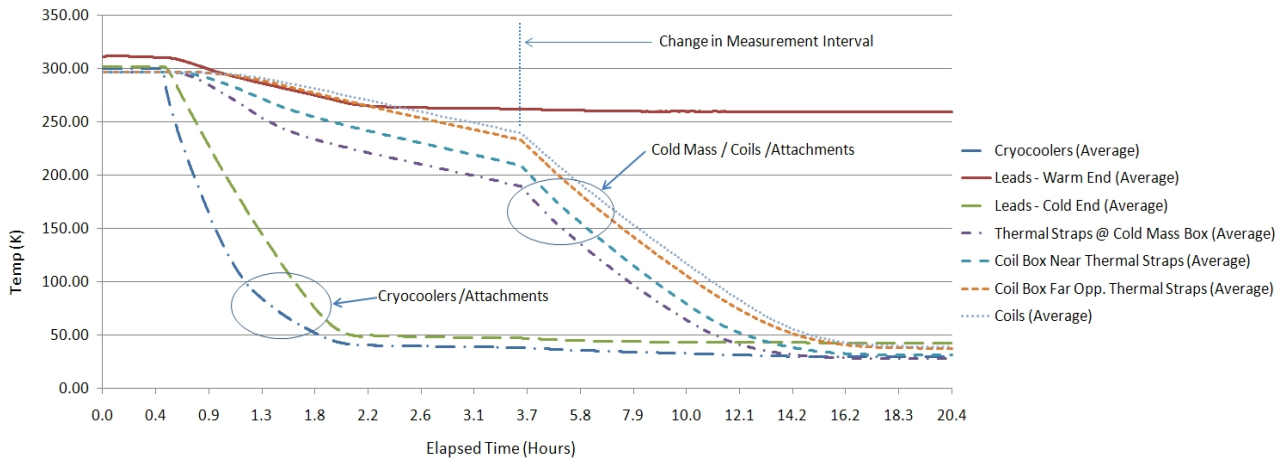

Figure 5: Time profile of magnet cool down

Thermal analyses were performed using temperature data for both the G-10 straps supporting the cold mass, and the thermal straps connecting the cold mass to the cryocooler. These two heat flows were equal, showing that nearly the entire heat load on the cold mass was from the G-10 straps and that the heat from the incoming HTS and the radiation load, was negligible.

Energy deposition experiments, similar to those performed in the first generation magnet cooled by helium [1], were carried out here as well. It was shown that the magnet cooled by cryocooler can remove the large amount of heat this is generated in FRIB magnets and can operate in a stable manner.

DISCUSSION

Early test results yielded temperatures which were not in agreement with calculated values and were inconsistent along the various cooling paths within the cold mass. Based on these results investigations were conducted which revealed that construction details created erroneous results. Most prominently, variations in bolting torques were creating variable contact pressures between parts which resulted in less than expected thermal performance. Also in one instance the substitution of indium for Apiezon-N vacuum grease resulted in lower heat transfer and higher temperature gradient between clamped surfaces. Finally, unreliable contact pressure between temperature sensors and the surfaces to be measured was determined to be the cause of some spurious readings. The manufacturer of the temperature sensors was contacted and an improved sensor clamp design was recommended and implemented. Subsequent measurement results regarding the temperature profile within the cold mass as well as the steady state temperature of the HTS coils showed smaller temperature

gradients at clamped surfaces and lower temperatures at the coil. Coil temperatures unpowered went from widely varying readings of 47 & 55 K to 38.3-38.6 K after reassembly.

This paper has described an effort to develop and demonstrate key technologies in the construction of a cryogen-free magnet designed around HTS coils. Using a magnet structure that is easily disassembled facilitates an iterative process of operations and improvement. Thermal data on the clamped joints, along with proven methods of temperature instrumentation are useful in future applications.

ACKNOWLEDGEMENTS

The authors wish to acknowledge the contributions of the Technical Staff under Ray Ceruti. Also to be thanked are P. Joshi and S. Dimaiuta for the design and implementation of a data acquisition system.

REFERENCES

- [1] Design, Construction and Test Results of a Warm Iron HTS Quadrupole for the Facility for Rare Isotope Beams, 20th International Conference on Magnet Technology, USA (2007).
- [2] <http://www.frib.msu.edu>.
- [3] AL125 Single Stage Gifford-McMahon Cycle Cryorefrigerator. Cryomech, Inc. 113 Falso Drive, Syracuse, New York USA 13211
- [4] L.J. Salerno, P. Kittela and A.L. Spivak, "Thermal conductance of pressed metallic contacts augmented with indium foil or Apiezon grease at liquid helium temperatures"
- [5] J.P. Cozzolino *et al.*, "Engineering Design of HTS Quadrupole for FRIB" paper TUP162 this conference